

KAPPA 43 DIMENSIONS

All Dimensions are WITHOUT Control Unit or Regulator

Dimensional Drawings are Shown in Millimeters. To Convert to Inches, Multiply Dimension x 0.03937

Specifications

KAPPA 43

Inlet Port - Hose Barb	1" HB
Outlet Ports - Hose Barb	(2) 1/2" HB
Bypass - Hose Barb	3/4" HB
Dimensions	9.5"L x 11.5"W x 10.0"H
Diaphragm Material	GREENTECH (Std) Buna-N (Opt)

Lubrication: Requires 20 oz. of Udor Lube 40W Premium Pump Oil. Alternate Oil: 30W non-detergent or 15W-40 non-detergent oil.

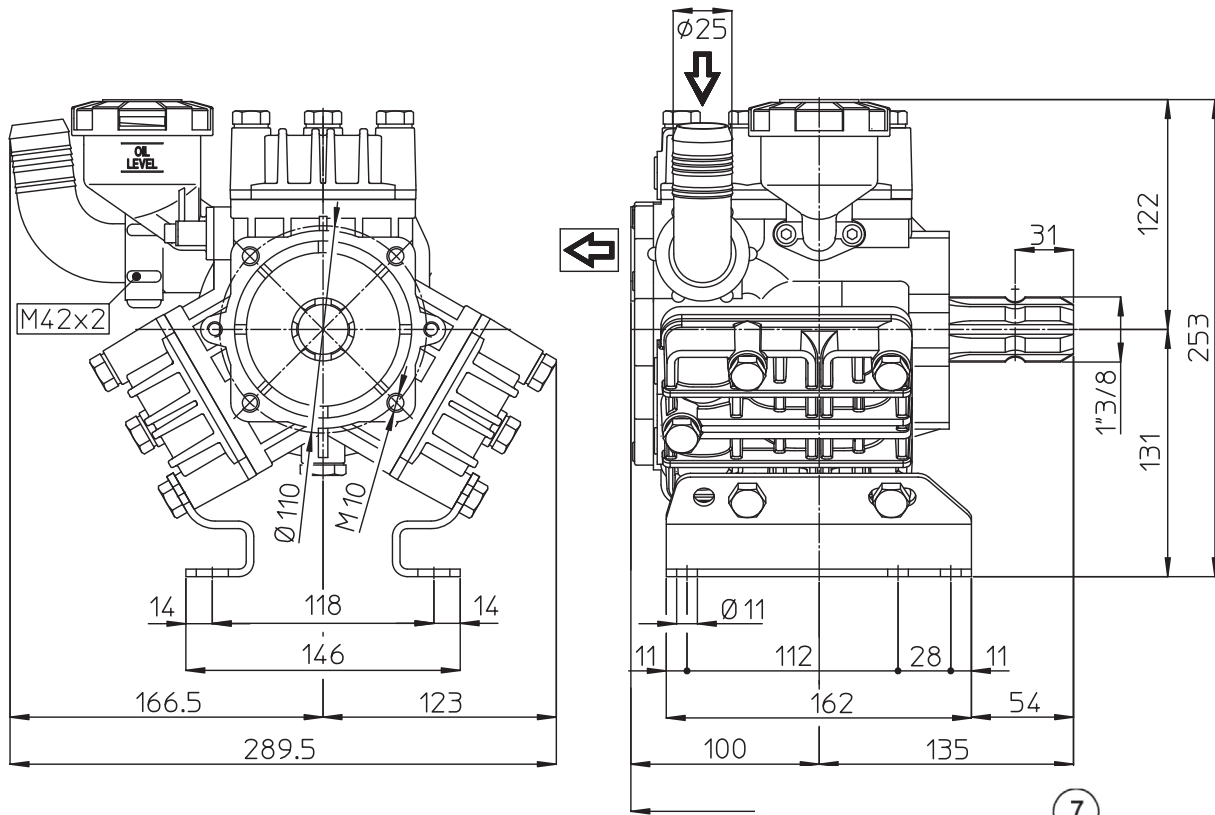

TORQUE SPECS

Ref.	Description	Ft./lb.	Nm
1	Diaphragm Bolts (Use Loctite 243)	18	25
2	Head Bolts	30	40
3	Pulsation Dampener Bolts	-	-
4	Inlet Flange Bolts	7	10
5	Bearing Flange Bolts	-	-
6	Oil Cup Bolts	6	8
7	Valve Cover Bolts	-	-

